

Hazard curve construction for icing events of overhead power lines

Zoltan Kovacs^{a*} and Pavol Hlavac^a

^aRELKO Ltd, Bratislava, Slovakia

Abstract: The paper describes the construction of hazard curves for icing events of overhead power lines to support the external natural event PSA of WWER440 type reactors. Ice loads are not measured in general by meteorological stations on the overhead power lines. Therefore, information on ice accretion needs to be recorded directly at correspondingly designed observation devices at the plant site. The Slovak Hydrometeorological Institute (SHMI) is performing measurement of ice accretion on the observation device at the plant site which is a line with length of 1 m and diameter of 30 mm. The thickness of the ice is being measured (mm) and the weight (g) is calculated from it. An example is provided for illustration of weight calculation from the thickness of the ice. The hazard curves of icing loads for different confidence levels are constructed and presented in the paper using the Gumbel distribution (named also extreme value distribution). Also the combinations of icing and other non-seismic natural external events are described and the frequency of occurrence quantification is presented in the paper.

Keywords: PSA, External Events, Overhead Power Lines, Icing, Hazard Curves.

1. INTRODUCTION

The design basis external events are considered in the project of the NPPs with occurrence frequency of $1.0E-2$ per year, e.g., once per 100 years. After the Fukushima accident the nuclear regulatory authorities over the world, also the Slovak Nuclear Regulatory Authority (UJD SR), required to analyze the impact of more severe external events with frequency of occurrence $1.0E-4$ - $1.0E-7$ per year. These external events can have higher impact on the plant than the design basis events. For such increased impact it is necessary to perform the risk assessment and to quantify the contribution to the total risk of plant operation. Also the impact of combination of these events must be analyzed because simultaneous occurrence of several events further increases the load on buildings and equipment.

The second part of the paper describes the overhead power lines in the plant. The third part is focused on the icing loads of the overhead power lines and construction of the hazard curves for the site. The part four presents the combinations of ice with other non/seismic natural external events. The conclusions are in the part five.

2. OVERHEAD POWER LINES IN THE PLANT

The 400 kV overhead power line is used to export electricity to the grid during plant operation. Given loss of 400 kV line due to external reason the turbogenerators (TG) reduce power to the level of self consumption. Reactor trip occurs given loss of the 400 kV line due to internal reason. Then, the self consumption of the plant is supplied from the reserve transformer which is fed from the 110 kV overhead power line from the electrical grid. Given simultaneous loss of both 400 kV and 110 kV lines the diesel generators (DG) are being started to supply the 6 kV busbars.

During reactor shutdown with available 400 kV line, the generator breakers are open and the power supply to the 6 kV busbars of the plant is provided from the grid using this line. After loss of 400 kV lines the power supply for residual heat removal is ensured by the reserve transformer which is fed from the 110 kV overhead power line. After loss of 110 kV line the diesel generators are started and connected to the 6 kV busbars. The schematic of plant self consumption is presented in Figure 1.

Figure 1: Schematic of plant self consumption

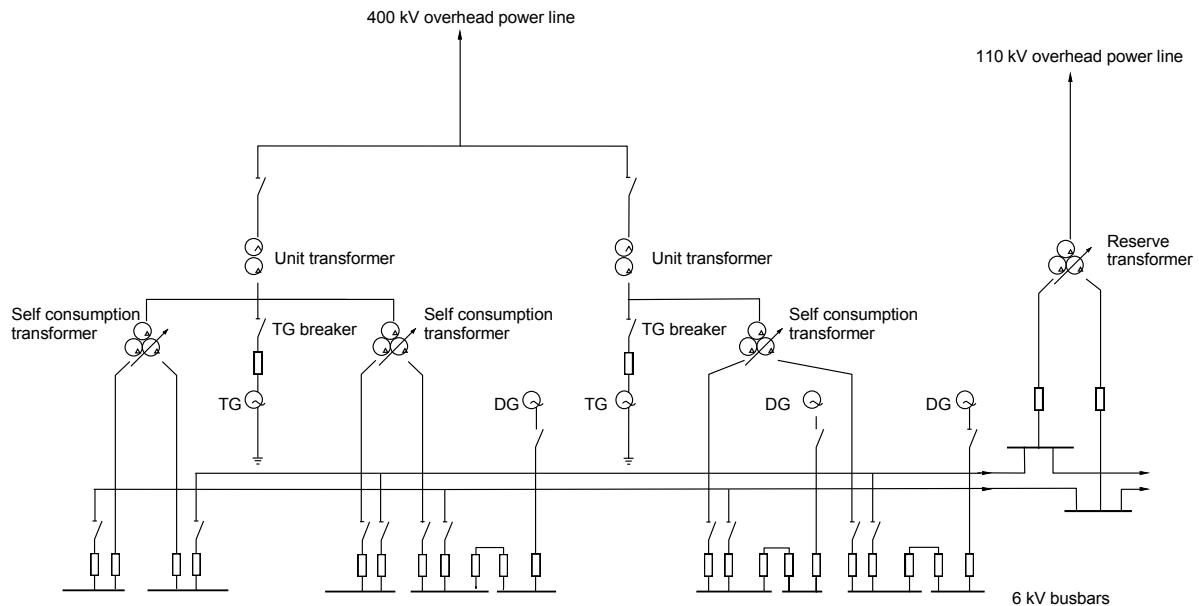

3. ICE LOADS OF THE OVERHEAD POWER LINES

The ice load can damage the overhead power lines and cause partial or total loss of offsite power of the plant. Different forms of ice loads of the overhead power lines are described in this part of the paper based on [1].

3.1. Atmospheric icing

Atmospheric icing is a general term for the processes where water in various forms freezes in the atmosphere and sticks to objects exposed to the air. In case of the overhead lines, there are two types of icing:

- precipitation icing, and
- incloud icing.

A third process, where water vapour is transformed directly into ice and forms hoarfrost, does not lead to significant loadings and is not considered further in the paper.

Ice accretion due to precipitation icing may occur in different forms, namely glaze due to freezing rain, wet snow accretion and dry snow accretion.

The regional and local topography affects the ice accretion. Coastal mountains along the windward side of the continents act to force moist air upwards, leading to a cooling of the air with condensation of water vapour and droplet growth with the consequence of incloud icing. The most severe incloud icing occurs above the condensation level and the freezing level on openly exposed heights, where mountain valleys force the moist air through passes and thus both lift the air and strengthen the wind. On the leeward side of the mountains, however, the descent of air mass results in internal heating of the air and evaporation of droplets thus protecting overhead power lines routed there against high ice accretion.

Precipitation icing may occur at any altitude. However, in general, the probability of precipitation icing is greater in the bottom of valleys in general than in the middle of valley sides, because of higher

occurrence of cold air. Since the air flow has an important effect, the ice accretion on overhead lines, which are routed transversely to a valley, is often higher than on other lines running along the valley. In case of lines mentioned first, an additional hazard is given because of the wind action having a higher probability of occurrence, simultaneously with ice accretion on the conductors.

3.2. Glaze due to freezing rain

The drops become supercooled when rain droplets or drizzle fall into a layer with cold air at a temperature below freezing point. They are still in the liquid (water) phase and do not freeze before they hit the ground or an object. The resulting accretion is a clear and solid ice, called glaze, often with icicles. This accretion is hard and strong, and therefore, difficult to remove. The density is 800 to 900 kg/m³, depending on the content of air bubbles in the ice. Freezing rain occurs mostly on wide planes or basins, where relatively thick layers of cold air accumulate during periods of cold weather. When a low pressure system with a warm front and rain penetrates the air, the cold and heavier air may remain near the ground and thus favour the formation of glaze during temperature inversion. Such a situation may persist until the upper wind may manage to mix the cold surface layer of the air with the warmer air aloft.

A similar situation may occur in the overlapping zones of cold air and warm air systems. The warmer air combined often with precipitation is lifted over the colder air, forming a frontal zone where precipitation is enhanced. Such a weather system was observed in Canada at the beginning of 1998 and resulted in massive and widespread damage to overhead lines. Often, there are only moderate winds during freezing rain events. Then, the amount of accumulated ice depends on the rate and duration of precipitation. Figure 2 depicts ice accretion due to freezing rain.

Figure 2: Ice accretion due to freezing rain

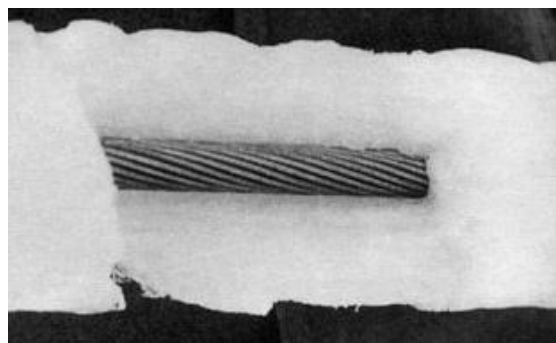

3.3. Wet snow

If snow flakes fall through warmer layers in the atmosphere, they start to melt when passing the zero degree zone. The wet snow flakes will contain a mixture of ice and water until they eventually melt totally into rain drops if the warm layer is thick enough. As long as they are only partly melted, they are sticky and may adhere to objects in the air flow, e.g., the conductors of overhead lines. The density may vary widely between 100 and 800 kg/m³, but mostly between 400 and 700 kg/m³. The density and intensity of wet snow deposits depend on precipitation rate, wind velocity and temperature. If the temperature drops below zero degree after the accretion, the ice will freeze into a hard and dense layer with strong adhesion to the objects. Wet snow events resulted in severe damage to overhead lines in the past.

3.4. Soft and hard rime due to incloud icing

Incloud icing is a process where supercooled droplets in a cloud or fog freeze immediately on objects in the air flow, for instance on overhead transmission lines in mountains above the cloud base. The

resulting ice accretion is called soft rime according to the density which is typically 200 to 600 kg/m³. Under similar conditions, hard rime is formed with a density between 700 and 900 kg/m³. At temperatures below -10°C, the water content of the air becomes smaller and less icing occurs. Under extreme conditions, high ice loads have also been observed at high winds and temperatures below -20°C. In Figure 3 a conductor is shown with ice formed in an incloud icing process.

Figure 3: Conductor with ice formed in an incloud icing process



3.5. Ice observations and measurements

Field ice data can be obtained through the following activities:

- Direct measurements of icing thickness or weight of ice samples, taken from observation installations or line conductors. Ice samples fallen on the ground from conductors can be used, if consideration is given to the shape of initial accretion on conductors.
- Measurements by devices that simulate ice accretion on conductors. Some devices currently used in a few countries consist of simple tube or cable assemblies installed near ground level for ease of observations.
- Estimation of icing using conductor tension or vertical component of weight at the insulator attachment point.
- Estimation of icing based on measurements of the conductor tension and sag.

Ice loading data are important not only to establish load criteria for design of supports but can also be useful in the planning stages of transmission networks and route selection of a specific line. So far other ice load information is not available, measurements lasting for at least ten years of field observation are necessary to establish a reliable database. The observation of extreme ice loads on existing overhead lines provides important information.

Meteorological models can be used as well to obtain basic information on ice loadings to be expected. The bases for such meteorological models are formed by the temperature, humidity, precipitation rate and wind direction to be expected.

SHMI is performing measurement of icing creation on the conductor with length of 1 m and diameter of 30 mm. The thickness of the icing is being measured (mm), then the weight is calculated from it. The data of the thickness of icing are presented in Table 1. The calculated values of the icing weight are presented in Table 2. For the purpose of the PSA the measurement for the time period 1996 – 2017 was taken into account.

Table 1: Data of the maximal icing in mm on the conductor

Winter	Month	Icing [mm]	Winter	Month	Icing [mm]	Winter	Month	Icing [mm]
1995-96	1	9	2003-04	2	4	2011-12	12	4
1996-97	1	14	2004-05	1	3	2012-13	12	4
1997-98	1	2	2005-06	2	13	2013-14	12	1
1998-99	1	26	2006-07	12	12	2014-15	1	1
1999-00	1	10	2007-08	12 - 1	9	2015-16	1	2
2000-01	1	33	2008-09	1	6	2016-17	1	9
2001-02	12	20	2009-10	2	4			
2002-03	1	10	2010-11	12 - 1	15			

Table 2: Data of the maximal icing load in g/m on the conductor

Winter	Month	Icing [g/m]	Winter	Month	Icing [g/m]	Winter	Month	Icing [g/m]
1995-96	1	439	2003-04	2	181	2011-12	12	181
1996-97	1	732	2004-05	1	134	2012-13	12	181
1997-98	1	88	2005-06	2	671	2013-14	12	43
1998-99	1	1581	2006-07	12	611	2014-15	1	43
1999-00	1	495	2007-08	12 - 1	439	2015-16	1	88
2000-01	1	2169	2008-09	1	280	2016-17	1	439
2001-02	12	1131	2009-10	2	181			
2002-03	1	495	2010-11	12 - 1	795			

The observed data were available in mm of icing thickness on the conductor. However, the load of the ice on the conductor should be known in g/m for evaluation the impact of extreme loads. Therefore, it was necessary to calculate the weight of icing from the available measurement information on the 1 m long conductor with the diameter of 30 mm.

An example is provided for illustration the weight calculation from the thickness of the icing. In Figure 4 the icing is shown on the conductor, where:

- a – thickness of icing [mm]
- r_1 – radius of the conductor [mm]
- r_2 – radius of the conductor with icing [mm]

Figure 4: Icing on the conductor

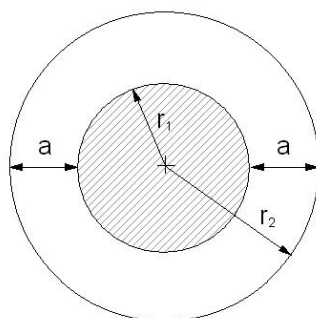

The diameter of the line is 30 mm, the radius is $r_1 = 15$ mm. Thickness of the icing is 33 mm. Such icing was recorded during the winter season 2000 - 2001.

The thickness of the icing is the sum of two a values, as it is presented on the Figure 4, e.g.:

$$33 \text{ mm} = a + a$$

Then, it is valid that:

$$a = \frac{33 \text{ mm}}{2} = 16.5 \text{ mm}$$

The values of radii „ r_1 “ and „ r_2 “ are applied in calculation, where

$$r_1 = \frac{d_1}{2} = \frac{30 \text{ mm}}{2} = 15 \text{ mm} ,$$

$$r_2 = r_1 + a = 15 \text{ mm} + 16.5 \text{ mm} = 31.5 \text{ mm}$$

In the next step the surface of the electrical line S_1 without icing and with icing S_2 are calculated:

$$S_1 = \pi * r_1^2 = 706.5 \text{ mm}^2$$

and

$$S_2 = \pi * r_2^2 = 3115.7 \text{ mm}^2$$

Then, the surface S_2 is reduced by the value of S_1 and the surface of the icing ring S is achieved:

$$S = S_2 - S_1 = 2409.2 \text{ mm}^2$$

Given that the surface of the icing ring S is available, and the length of the electrical line is $l = 1 \text{ m} = 1000 \text{ mm}$, the volume of icing can be calculated:

$$V = S * l = 2409.2 \text{ mm}^2 * 1000 \text{ mm} = 2409200 \text{ mm}^3 = 0.0024092 \text{ m}^3$$

A conservative value of the icing density is considered $\rho = 900 \text{ kg/m}^3$ [1].

The load of the line with the length of 1 m is:

$$m = V * \rho = 0.0024092 \text{ m}^3 * \frac{900 \text{ kg}}{\text{m}^3} = 2.169 \text{ kg} = 2169 \text{ g}$$

All other load values were calculated from the Table 1 using the same approach.

The hazard curves of icing with different confidence levels are presented in Figure 5 and 6. The Gumbel distribution was used to construct the curves [2]. The curves from Figure 6 are used in the PSA of the Mochovce plant where the measurement was done.

The return periods for different confidence levels depending on the icing load are presented in Table 3.

There are 9 icing areas: I0, I1, I2, I3, I5, I8, I12, I18 and IK [4]. The allowed weight of icing on the line (with 30 mm diameter conductor of the line) in the given icing area is specified by the number at the symbol I, e.g., 1 kg/m in area I1, 2 kg/m in area I2 and so on. The exception is the area I0, where the allowed weight is 0.5 kg/m. In the icing area IK the allowed weight of icing is 18 kg/m.

The map of icing areas in Slovakia is presented in Figure 7. The Slovak plants are located in the area IO where the icing generation is very small [3].

Figure 5: Hazard curves of icing with the 5%, 50% and 95% confidence levels

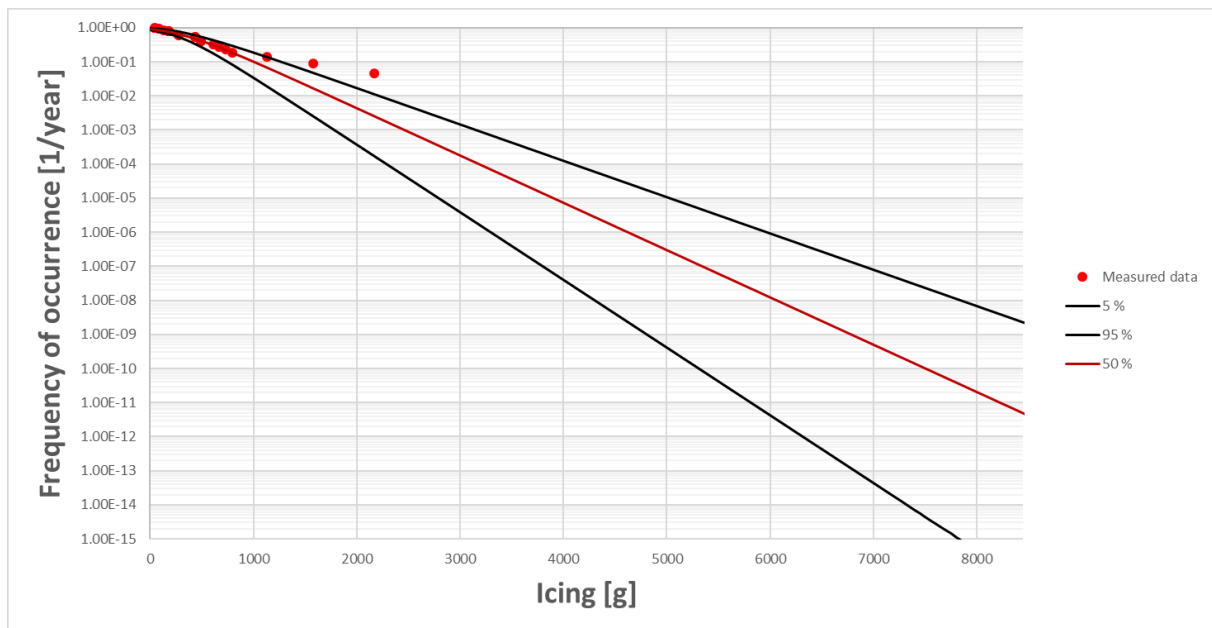

Figure 6: Hazard curves of icing with all calculated confidence levels

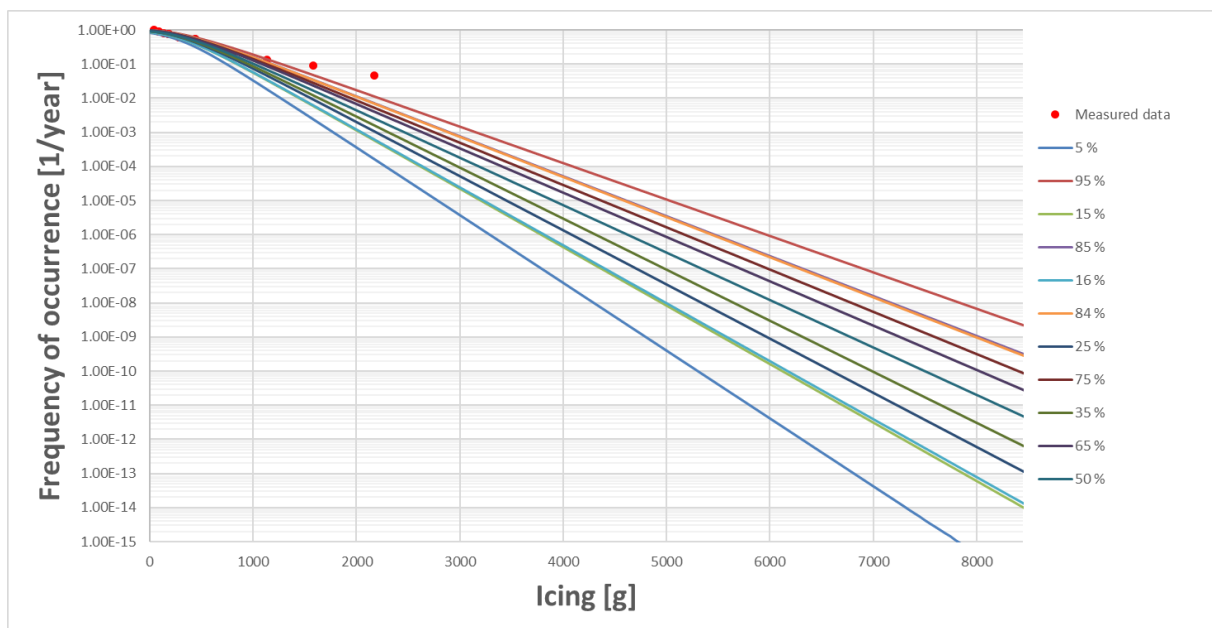
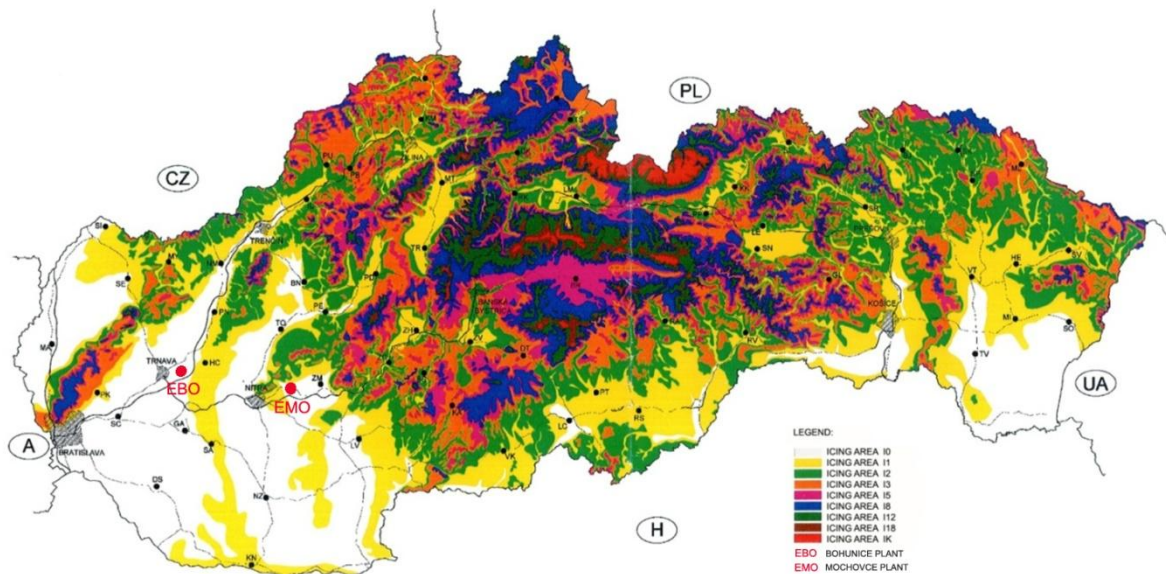

Table 3: Return period for different confidence levels depending on the icing load

Return period [year]	Confidence levels [g]										
	50%	5 %	95 %	15 %	85 %	16 %	84 %	25 %	75 %	35 %	65 %
5.00E+00	422.02	294.53	549.51	341.69	502.35	344.95	499.10	369.75	474.30	392.16	451.89
1.00E+01	1010.96	745.40	1276.52	843.63	1178.30	850.41	1171.52	902.07	1119.86	948.75	1073.17
1.50E+01	1527.29	1115.21	1939.37	1267.63	1786.94	1278.15	1776.42	1358.31	1696.26	1430.75	1623.82
2.00E+01	1963.05	1423.42	2502.67	1623.02	2303.07	1636.80	2289.30	1741.77	2184.33	1836.63	2089.46
2.50E+01	2466.82	1778.04	3155.60	2032.82	2900.83	2050.40	2883.25	2184.38	2749.27	2305.47	2628.18
5.00E+01	3186.81	2283.42	4090.20	2617.58	3756.04	2640.63	3732.99	2816.37	3557.26	2975.19	3398.44
1.00E+02	3403.51	2435.35	4371.68	2793.47	4013.56	2818.17	3988.86	3006.51	3800.52	3176.71	3630.32
2.00E+02	3906.67	2787.90	5025.45	3201.72	4611.62	3230.27	4583.07	3447.91	4365.44	3644.59	4168.75
5.00E+02	4409.82	3140.24	5679.41	3609.85	5209.80	3642.25	5177.40	3889.22	4930.43	4112.41	4707.23
1.00E+03	4843.21	3443.62	6242.81	3961.32	5725.11	3997.03	5689.39	4269.29	5417.13	4515.35	5171.08
1.00E+04	5346.37	3795.73	6897.00	4369.30	6323.43	4408.87	6283.86	4710.51	5982.22	4983.12	5709.61
1.00E+05	6066.21	4299.37	7833.05	4952.91	7179.51	4998.00	7134.42	5341.70	6790.72	5652.32	6480.11
1.00E+06	6786.06	4802.91	8769.21	5536.46	8035.65	5587.07	7985.04	5972.85	7599.27	6321.49	7250.63
1.00E+07	7505.90	5306.37	9705.44	6119.96	8891.84	6176.09	8835.71	6603.96	8407.85	6990.65	8021.16
1.00E+08	8945.60	6313.15	11578.05	7286.88	10604.33	7354.06	10537.15	7866.14	10025.07	8328.93	9562.28
1.00E+09	8225.75	5809.78	10641.72	6703.43	9748.07	6765.08	9686.42	7235.06	9216.44	7659.79	8791.71

Figure 7: Map of icing areas in Slovakia



4. COMBINATIONS OF ICING AND OTHER EXTERNAL EVENTS

The following combinations of icing and non-seismic external natural events were identified for the plant sites:

- icing - extreme wind,
- icing - extreme snow,
- icing - extremely low air temperature, and
- icing - extreme wind - extreme snow.

A combination of events is assumed relevant only if the simultaneous occurrence of the events is dependent. Given that two rare events occur independently, the combined occurrence is so improbable that the combination can be considered insignificant.

The qualitative and quantitative assessment is performed for the identified relevant combinations of two events. If after a qualitative assessment a combination is still considered relevant, the frequency of the event combination is calculated by using the frequencies of occurrence of the single events. These frequencies are estimated using the extreme value theory from the hazard curves and input data of the events for at least 30 years. The event with a lower frequency is assumed to be occurred and the conditional probability for the other event to occur is estimated.

The frequency of combination with two events is calculated by multiplication of the lower single event frequency and the conditional probability of the other event.

The frequency of combination with three events is calculated by multiplication of the lowest single event frequency and the conditional probabilities for the other events.

The frequency is determined from the hazard curves of the site. The conditional probability of event occurrence is calculated for example according to the occurrence in the different months of the calendar year.

The following frequencies were calculated for the combinations:

- icing - extreme wind = $1.35E-4 \times 0.5 = 6.75E-5$ /y
- icing - extreme snow = $9.92E-4 \times 0.25 = 2.48E-4$ /y
- icing – extremely low air temperature = $5.16E-4 \times 0.25 = 1.29E-4$ /y
- icing - extreme wind - extreme snow = $1.35E-4 \times 0.42 \times 0.25 = 1.42E-5$ /y

The extreme wind, extreme snow and extremely low air temperatures constitute the values very closed or behind the design basis values of the plant.

5. CONCLUSION

After selection of extreme meteorological events applicable for the plant sites the hazard analysis was performed. The hazard is shown in the form of hazard curves. The hazard curves of the icing are presented in this paper.

The following tasks will be performed in the next step for icing and its combinations within the PSA of extreme meteorological events:

- fragility analyses of the overhead lines, effected structures and components,
- analysis of the plant response,
- implementation of icing and its combinations into the PSA model, and
- quantification of the risk due to icing and its combinations and interpretation of the results.

References

- [1] Kiessling, F. et al.: *Overhead power lines: planning, design, construction*, Springer, 2014, Berlin
- [2] Haan, L. and Ferreira, A.: *Extreme value theory, an introduction*, Springer, 2006, New York
- [3] *Summary report of SHMU for the Mochovce site*, SHMU, 2011, Bratislava, (in Slovak)
- [4] Fecko, S. et al.: *External electrical lines*, FEI-STU, 2010, Bratislava, 2010, (in Slovak)