

# Producing effective maintenance strategies to control railway risk

Claudia Fecarotti and John Andrews

*Resilience Engineering Research Group, Faculty of Engineering, University of Nottingham, Nottingham, UK, NG7 2RD*

**Abstract:** This paper describes the main features of a modelling framework that sets out a systematic approach to railway infrastructure asset management enabling decisions to be made based not only on costs but on service performance and safety. First, the framework structure is briefly described, then the main focus is on the discussion of the modelling capabilities that will support decisions on the asset interventions that have an impact in reducing the risk related to the use of the railway infrastructure. Standard industrial techniques such as event trees can be used to lay out all the possible paths leading from an initiating event to a given outcome through a series of success and failure events. Only the probability of the intermediate events related to failures of the infrastructure can be controlled by the Infrastructure Operator through maintenance. State-based stochastic models using Petri nets are developed for each asset type to predict the asset response to maintenance, including the probability of the different failure modes. Such predictions can support the selection of the most effective maintenance strategies that contribute to reduce the risk related to the use of the infrastructure. An example is provided for evaluating the risk of train derailment due to track geometry faults.

---

**Keywords:** Railway asset management, degradation and maintenance modelling, Petri nets, derailment.

---

## 1. INTRODUCTION

The railway system consists of a complex and diverse portfolio of assets including the track, switches and crossings, signalling systems, communication systems and electrification systems as well as the civil structures such as bridges, tunnels and stations. Many railway assets are safety critical, where a failure, malfunction or degraded condition may result in loss or severe damage to equipment and the potential for injury or fatalities to the workforce and passengers. Maintenance is vital to control the risks related to the use of the railway infrastructure, especially as assets age and degrade with time and usage. Each asset undergoes its own degradation and failure processes and requires a set of maintenance interventions to control the system state. Predicting the effect of a range of potential management strategies on the evolution of the assets' conditions as well as the consequent impact on safety and service performance, is a very desirable capability of any asset management system. Asset management decisions are made so that performance and safety targets, usually specified at route or network level, are met and costs are minimised. Bespoke models accounting for the complexity and interaction of degradation, failure and maintenance process are needed to investigate the asset response to a given management strategy. Such models shall enable prediction of the future asset conditions, types and number of interventions as well as the probability of the asset's failure modes following the implementation of any management strategy. It is also necessary to link predictions on asset performance with predictions of service performance, safety, infrastructure availability and whole life costs at route or network level. This would enable to demonstrate how the implementation of a given management strategy will deliver the route/network objectives. Furthermore, across-assets dependencies which are functional, operational and economical, require to integrate such models into a whole system representation. There have been a few attempts to develop more structured approaches to the management of the railway system, and they are all based on the application of Reliability Centered Maintenance (RCM). The applicability of RCM approaches to the railway system have been investigated in contributions such as [1] [2]. RCM is a well-established methodology focusing on system functions rather than the system "hardware" in order to support preventive maintenance planning, aimed at reducing maintenance costs while improving reliability and safety [3]. In [1] the authors present the

results obtained from the European project RAIL aiming at studying the applicability of RCM to the railway infrastructure system and develop common maintenance procedures across Europe. They developed a RCM methodology and toolkit to perform RCM analysis; the methodology apply failure modes and effect criticality analysis (FMECA) to identify functional failures, failure modes and their causes for the railway assets. Macchi et al. [2] present a modelling methodology to support maintenance management of the railway infrastructure based on reliability analysis. A main objective of their methodology is to provide a capability for the assessment of maintenance plans accounting for their impact on service levels. Both contributions have concluded that the large scale of the railway system is a main concern when applying RCM in its traditional form for railway maintenance planning. The methodologies for reliability assessment traditionally applied in RCM such as FMECA and logic decision trees, do not always enable the complexity of the degradation and intervention processes to be taken into account, as well as the complexity of the interaction between components. Furthermore, decisions made by the infrastructure managers must take into account not only costs, but the requirements in terms of both safety and service performance in order to be competitive with other transportation industry.

In order to address such challenging requirements, a modelling framework to set out a systematic approach to railway infrastructure asset management has been developed by the authors, which overcome some of the limitations of traditional RCM. The framework embeds a library of models which enable decisions on the assets interventions to be made based not only on costs but on service performance and safety.

## **2. THE MODELLING FRAMEWORK**

The framework supports a systematic and objective decision making process to determine the required asset interventions at the required level (asset, route, network) in order to meet route and network safety and service objectives for the minimum whole life cost. In order to take into account dependencies across assets and between different parts of the network, the framework will enable decisions to be made based on a whole-system approach. The importance of a whole system approach to the decision making process cannot disregard the necessity of a detailed consideration of each individual asset. Indeed, each asset undergoes specific degradation and failure mechanisms and requires specific types of intervention activities. It is important to develop methods capable of predicting the evolution of the asset state over time and the activity volumes following the implementation of any intervention strategy. Such predictions are the basis for assessing and comparing different intervention strategies and eventually selecting the optimal combination of interventions for all assets along a given section, route or network. The framework therefore embeds models with different levels of detail, from the individual assets to the entire network. It also specifies procedures to assemble all asset models into a whole system model. This includes identifying dependencies across different asset disciplines (cross-asset dependencies) and neighbouring sections such as inspection, sharing of resources (equipment, personnel), track possession, opportunistic maintenance, degradation/repair of connected assets, assets renewals. Models that link assets management strategies to high level performance indicators (service performance, safety, infrastructure availability, whole life costs) will enable the forecasting of the impact of each asset performance on service performance and safety.

The framework has the structure of a library of databases and models as follow:

- Databases section
  - Unprocessed data
  - Processed data
- Models section
  - Network topology model
  - Cost analysis tool
  - Assets models
    - Degradation models
    - Maintenance and maintenance effectiveness models
    - Asset state models

- Service provision model
- Safety models
- Optimisation models to support the decision making process (these also can be specified at different levels of detail: asset level, section/route/network level)

The models section will accommodate a network model representing the network topology for positioning and routing purposes, asset models for each individual asset group, a service provision model for the assessment of the effects of any asset management decision on service performance, and a set of safety models for the assessment of each potential hazard. The network topology model provides a multilevel description of the network, spanning from a microscopic representation where details of the infrastructure are provided at signal berth level, to a macroscopic indication of major stations and connecting links. Linking this to the asset register would enable individual assets to be located along the network. It will also contain information related to local factors, such as environmental and geological information and information regarding route criticality, line traffic speed and tonnage. The asset state models combines the degradation, failure and maintenance processes to investigate the assets response to maintenance. These are the core of the framework as they enable to predict the future asset state, the whole life costs, the intervention work flow and the likelihood of each of their possible failure modes occurring. The results from the asset state models will feed into the higher, system level route and network models and also the models which predict the influence the assets have on service and safety. The modelling framework also specifies the procedure by which all asset models for each piece of infrastructure and sub-system can be assembled to form the whole system model at the relevant level. This process implies the identification of the dependencies between both assets and processes. A schematic representation of this process is illustrated in Figure 1. This shows the structure for the framework and will feature a clear line of sight for the way in which the models are used and the data collected and analysed to support the prediction of specified key performance measures.

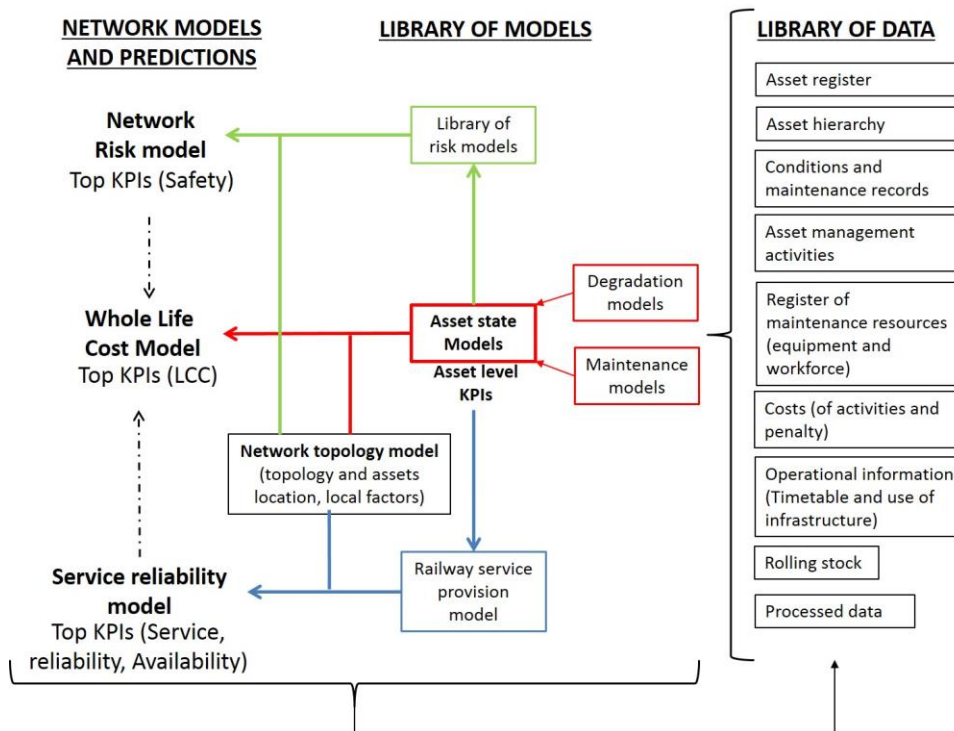

Figure 1 Schematic representation of the modelling framework structure

## 2.1 Key Performance Measures

In order to assess the effectiveness of any asset management strategy, it is necessary to predict some measure of performance that can then be compared for different strategies. Key Performance Indicators

(KPIs) are defined both at asset and network level and are representative of the following four system parameters:

- Asset conditions
- Service reliability
- Safety
- Whole life costs

For each asset discipline, the framework enables the forecasting of the future asset conditions as well as the asset reliability and availability. The framework will also include the capability to relate the asset performance indicators to the network performance indicators. Network performance indicators shall be representative of the railway service reliability, for example in terms of train delays and cancellations. The predicted risk or frequency of occurrence for each potential hazardous event affecting either the passengers or the workforce is also required. Finally, cost indicators which will be combined to yield the whole-life costs of managing the railway assets.

### 3. APPROACH TO RAILWAY RISK ASSESSMENT

The first step for the construction of the safety model will be to identify the risks related to the use of the infrastructure, such as derailment and collision. Fault tree and event tree techniques are accepted industrial ways to evaluate risks in railways. These two techniques are often used in combination. The event tree lays out all the possible paths leading from an initiating event to a given outcome which determines the consequences. It enables the evaluation of the frequency of each consequence as well as the risk of the hazardous event. Fault trees are used to evaluate the probability of the intermediate condition, which in the railway case include the failure modes of railway assets. One of the risks related to the use of the infrastructure is train derailment. Let us focus on the risk of derailment due to track vertical geometry issues on plain line. Track vertical geometry degrades over time due to age and the passage of traffic. If maintenance is not planned appropriately, geometry degradation can reach some safety thresholds that require the imposition of speed restrictions or line closures to control the risk of derailment. Figure 2 depicts a simplified event tree for train derailment due to track geometry issues.

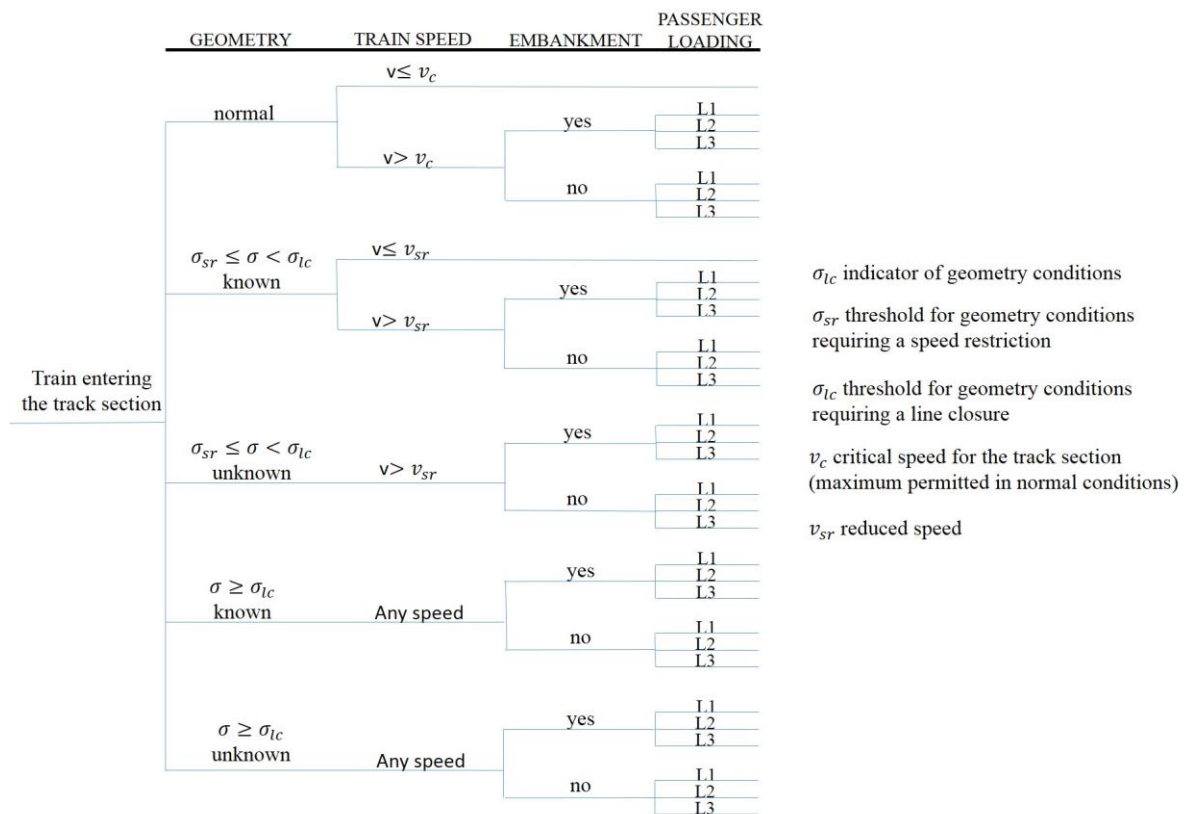
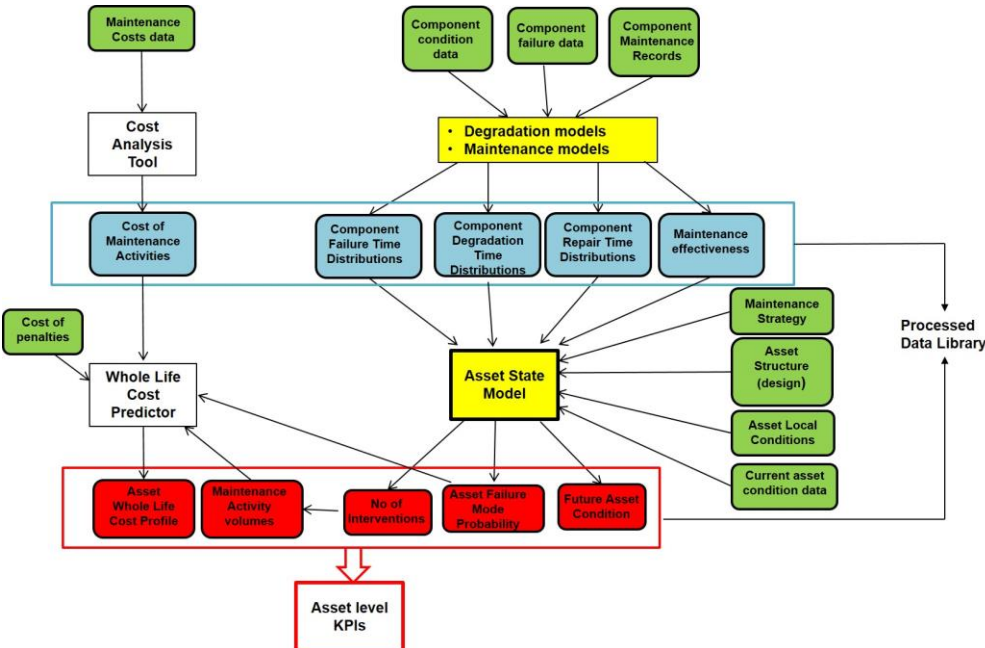

Figure 2 Simplified event tree for train derailment due to poor track geometry.

In this representation, the initiating event is a train running through the track section. Due to poor geometry, the track may not safely support the train passing through. Speed restrictions and line closure are imposed to control the risk as soon as the degraded states are detected. Nonetheless, train may still run before the degraded state is discovered, or train can exceed the imposed speed limits due to either a driver error or a failure of the signaling. The consequences and corresponding frequencies will vary depending on the type of train involved, its loading, its speed, the level of track geometry degradation and whether such state is known or not. The location of the accident also affects the consequences, for example if the track is on an embankment, higher consequences can be expected if the derailed train falls down the bank. Both the consequences and the risk will also vary during the day, as the frequency, passenger loading and type of service change. Of the events potentially leading to a derailment, the Infrastructure Manager only has control on those related to the state of the track. Although it is not possible to control when such failure modes will occur, it is possible to lower their probabilities through the right combination of inspection and maintenance. Fault trees are commonly used to evaluate the probability of the intermediate events. However, the fault tree technique is not capable of accounting for the complex interaction between degradation, failure and intervention processes involving the railway assets. State-based stochastic approaches are better suited, and the Petri net method in particular exhibits advantageous features when modelling maintenance of ageing infrastructure. The Petri net approach is chosen here to develop the asset state models which provide a mean to predict the probability of each failure mode for any inspection and maintenance strategy.

**4. ASSET STATE MODELS**

The *asset state models* combine the degradation and failure processes of the asset components with the interventions that can be performed and predicts the future asset state. Figure 3 shows a flow chart describing the input-output of the asset state models.



**Figure 3 Asset models flowchart.**

The degraded states that trigger different types of intervention are represented, as well as all the possible failure modes. All the possible intervention activities are modelled, and the effectiveness of maintenance is accounted for if supported by data. The model is constructed accounting for the asset structure (how components link together) and the rules to carry out each maintenance task. By switching on and off the possible maintenance activities, the models enable to evaluate any intervention strategy. Analysis of the asset state models will predict the future asset state, the number of interventions performed and the likelihood of each of the possible failure modes occurring within a given period of time. These results

are converted into the asset level KPIs for the asset of interest. Cost analysis tools are then needed to evaluate the cost of different maintenance activities and interventions given the historical maintenance cost data contained in the databases section. By combining the volume of each activity performed, as predicted by the asset model, with the costs of each activity as provided by the cost analysis tool, the whole-life cost of the asset for any given management strategy can be predicted. The asset state models provide the foundation of the other modelling activities – the link being through the probabilities of residing in the failed state. These failure probabilities are inputs to both the service disruption model and the safety performance models. In addition these are the basic elements which are linked together to form a ‘system’ model which can be used for a route analysis or a whole network analysis.

**4.1 Computational methodology: Petri nets**

Petri nets are a formalism for modelling complex distributed systems characterised by concurrency and dependency, synchronization and resource sharing. Petri nets provide a valuable mathematical and graphical description of the system behaviour. A Petri net is a directed, weighted bi-partite graph where nodes are places and transitions connected by arcs [4] [5]. Places may represent possible different states for a component, such as working and failed, or different levels of degradation, or different phases of a process. Tokens are held in places and the number of tokens in each place, referred to as marking of the Petri net, represents the state of the system at a given time. The flow of tokens through the network represents the dynamic of the system and is governed by transitions. Transitions usually represent events that cause the state of system to change. Such events may be components’ failures and repairs. Arcs only connect places with transitions (input arcs) and vice versa (output arcs). A particular type of arc called inhibitor can be used to stop the firing of a transition under certain circumstances. Arcs are characterised by a multiplicity. The marking of the net along with the multiplicity of the arcs determine the enabling conditions for each transition. Petri nets in which a firing time is associated to transitions are called Timed Petri net. Furthermore, this firing time can be either deterministic or stochastic. In the latter case, the firing time of the stochastic transitions is sampled from the appropriate stochastic distribution. Firing of transitions is ruled as follow:

- The transition must be enabled, namely the number of tokens contained in the input places must be at least equal to the multiplicity of the associated input arcs, and the number of tokens in the places connected by inhibitor arcs must be lower than the arcs multiplicity.
- Once the transition is enabled, the transition will fire after a period of time  $t$  whose value depends on the type of transition. Deterministic transitions have an associated fixed firing time which is 0 for immediate transitions. For stochastic transitions the firing time is sampled from a probabilistic distribution.

When the firing time is reached and the transition fires, a number of tokens is removed from the input places, which is equal to the associated arc multiplicity. Analogously, a multiplicity of tokens is added to the output places. In a PN places are represented by circles, transitions by rectangles and tokens by small black dots contained into places. Figure 4 shows the same PN with different markings; the first marking is such that transition T1 is not enabled, the second marking enables transition T1 which by firing produces the third marking.

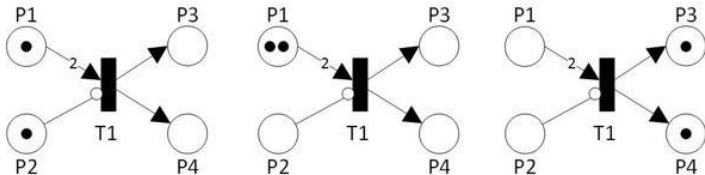

Figure 4 PN with different markings before and after firing

PNs provide a stochastic technique which allows far greater detail in the modelling of the assets degradation processes and complex management strategies in comparison to the alternatives whilst maintaining a manageable model size. PN allow to easily account for any distribution of degradation and failure times so that increasing failure rate typical of components subject to wear-out can be considered. PN also enable the modelling of complex maintenance processes including condition and



risk based inspection and maintenance, replacement prior to failure based on either age, condition or use, reactive repair, refurbishment and renewal and all the rules for the implementation of such activities. An additional and very handy feature of PN models is their modularity. Models of assets consisting of many interacting components can be built up in modules giving the model a modular structure easier to analyse. Monte Carlo simulation is the most common solution techniques for PN models, which produce distributions of the output variables of interest rather than point estimates delivered by alternative methods. PN models have been proposed in the literature as support tools for the asset management of railway track [6] [7] [8], railway bridges [9] [10] [11] and OLE [12]. Due to the advantages of PN models over alternative methods as described above, and given that such modelling technique has been successfully applied to develop asset management models for a variety of railway assets, the PN method is suggested here as a potential single modelling and computational tool for developing the integrated asset models. In the following section, an example of asset state model is developed for the investigation of track geometry maintenance strategies.

## 4.2 Track geometry and maintenance model

A track geometry degradation and maintenance model has been developed to simulate how track geometry changes over time due to ballast degradation and the interventions that can be performed. The passage of traffic causes a variation of the rails vertical position; inspection is performed periodically by running Track Recording Vehicles along the track that measure the location of the rails and provides the variations of the rails vertical position over 1/8<sup>th</sup> mile section. Based on the output of the inspection process, maintenance is scheduled if necessary. If the state of the track is discovered to be above a safety threshold, than a speed restriction or even a line closure can be issued while an emergency repair is scheduled and performed. Tamping machines are used to improve geometry conditions. However, while improving track geometry conditions, tamping also damage the ballast, causing the track geometry degradation rate to increase over time with the number of tamping performed [13]. In the model, three processes are modelled: the phased deterioration process, the inspection and the maintenance process. The deterioration process is represented in Figure 5 where places P1 to P6 indicate seven possible states for the track.

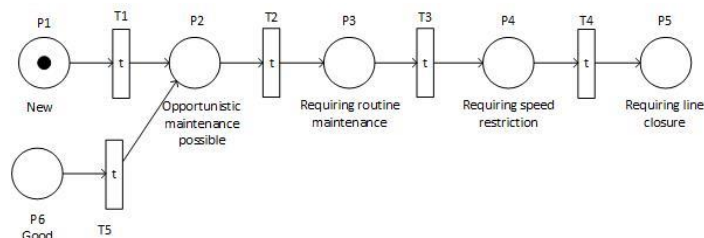

**Figure 5 Degradation process.**

These states are in order: new, state where opportunistic maintenance could be performed, state requiring routine maintenance, a state requiring speed restriction, a state requiring a line closure and a good state following effective maintenance. When maintenance is carried out, the track geometry is never restored to as good as new conditions. Therefore place P6 is used here to indicate the best possible state achievable following repair. Each state is characterised by an SD value of the vertical profile as defined above. A given state is entered when the corresponding SD value is reached. Transitions between these states are ruled by transitions T1 to T5. The times to degrade from one state to another have been seen to be distributed according to a 2-parameter Weibull distribution [13]. Therefore for transitions T1 to T5, the firing time is sampled from a 2-parameter Weibull distributions that indicates the distribution of times to reach a certain SD value. Inspection of track geometry is carried out periodically by means of measurement trains. In Figure 6, the loop P13-T13-P14-T14-P13 represents the inspection process; place P14 is marked if inspection is not currently underway. Transition T14 represents the start of the inspection which occurs periodically with a given frequency  $\theta$ . T14 is therefore a deterministic transition which fires with frequency  $\theta$ , removing the token from P14 and adding a token in P13. Such new marking indicates that the inspection is now being performed. A token in P13 will contribute to enable

transitions T6 to T9 if the track is currently in any of the degraded states requiring intervention (P2 to P5).

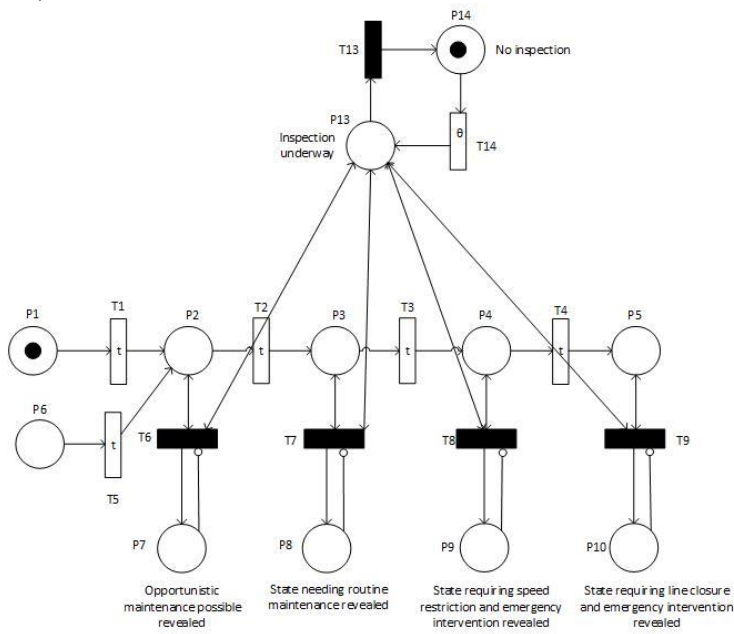

**Figure 6 Degradation and inspection**

The revealed states are represented by places P7, P8, P9 and P10. Once a degraded state is revealed, the intervention can be scheduled according to the urgency required by the severity of the degraded conditions as indicated in Figure 7.

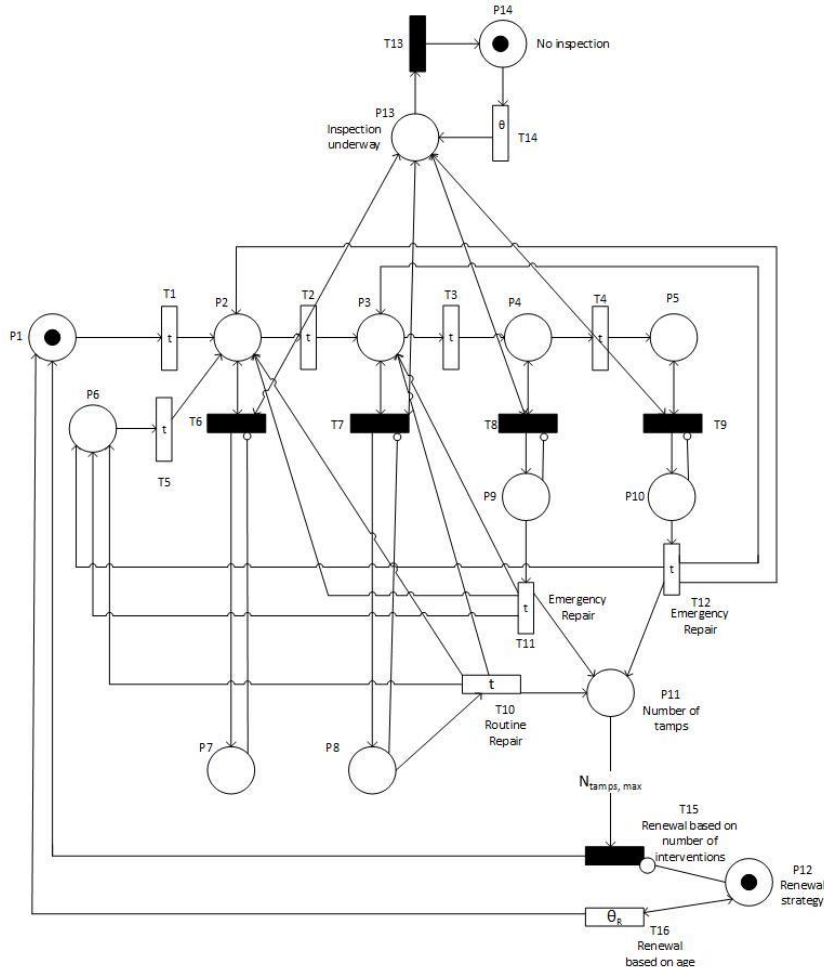



## Figure 7 Track geometry and maintenance model

Transitions T10 represents the scheduling and performing of routine maintenance while T11 and T12 represent emergency and immediate repair. The time to schedule and perform maintenance is assumed to be normally distributed. The model also accounts for the fact that the effectiveness of the maintenance process can vary. The analysis of condition and maintenance records shows that the effectiveness of tamping decreases with the number of interventions previously performed. Therefore, once maintenance is carried out, the state of the track can be brought back to either a good state (place P6 will be marked) or worst with given probability. Similarly, it has been shown that the rate of degradation increases with the number of tamping. This is accounted for in the model by varying the distributions of times to degrade for each of transitions T2, T3, T4 and T5 based on the number of tamping performed. Ballast renewal is also modelled, either based on age or on the maintenance history. Transition T15 indicates the renewal based on the number of tamps previously performed. This is an immediate transition and will fire as soon as the marking in its input place P11 has reached a given threshold  $N_{\text{tamps,max}}$ . Transition T16 indicates the renewal based on age. This is a deterministic transition with a firing frequency  $\theta_R$  equal to the inverse of the ballast assumed lifetime. Marking of place P12 represents the renewal strategy selected. If P12 is marked the renewal is based on age and transition T16 is enabled, while if P12 is empty then transition T15 is enabled. Both transitions T15 and T16 are reset transitions; this means that when they fire, the marking of the entire PN is reset to new conditions (P1 and P14 marked and all the remaining places empty). Due to the stochasticity of the deterioration and intervention processes, Monte Carlo simulation is used to analyse the track section PN model.

### 4.2.1 Model analysis and results

In order to show the capabilities of the track geometry model a case study representative of a section of track within a mass transit line has been carried out. The threshold values of SD of vertical top defining the different degraded states are summarised in Table 1.

**Table 1 SD threshold values for each degraded state**

$SD_{op}$	$SD_{rm}$	$SD_{sr}$	$SD_{lc}$
opportunistic maintenance is possible (associated to place P2)	routine maintenance is required (associated to place P3)	SR and emergency repair required (associated to place P4)	LC and immediate repair required (associated to place P5)
1.5	1.8	2.5	3.5

Table 2 details the parameters of the Weibull distributions associated to each stochastic transition representing the degradation between different degraded states.

**Table 2 Weibull parameters associated to each stochastic transition representing degradation**

T1		T2		T3		T4		T5	
$\beta$	$\eta$	$\beta$	$\eta$	$\beta$	$\eta$	$\beta$	$\eta$	$\beta$	$\eta$
1.5	600	1.5	500	1.6	370	1.7	280	1.8	740

Simulations have been run to investigate the response of the asset to different maintenance strategies during a 35 years time period. The different maintenance strategies are obtained by varying the inspection period (time between two consecutive inspections), the mean time to schedule and perform routine maintenance, and the mean time to carry out an emergency intervention. The following assumptions are considered:

- Inspection is performed at regular intervals. This correspond to transition T14 being deterministic and firing with frequency  $\theta$ .
- Transitions T10, T11 and T12 represent the scheduling and execution of maintenance - routine (T10), emergency from speed restriction (T11) and immediate from line closure (T12) respectively. These transitions are stochastic with time distributed according to a lognormal distribution.

Twelve maintenance strategies have been analysed, details given in Table 3.

**Table 3 Maintenance strategies resulting from the combination of all maintenance parameters in Table 2.**

Strategy	Inspection period (T14)	Mean time to perform routine maintenance (T10)		Mean time to perform maintenance from speed restriction (T11)		Mean time to perform immediate repair (T12)	
	$\theta(\text{days})$	$\mu(\text{days})$	$\sigma^2(\text{days}^2)$	$\mu(\text{days})$	$\sigma^2(\text{days}^2)$	$\mu(\text{days})$	$\sigma^2(\text{days}^2)$
1	15	20	5	5	1	1	0.1
2	15	20	5	10	2	1	0.1
3	15	30	5	5	1	1	0.1
4	15	30	5	10	2	1	0.1
5	15	40	10	5	1	1	0.1
6	15	40	10	10	2	1	0.1
7	120	20	5	5	1	1	0.1
8	120	20	5	10	2	1	0.1
9	120	30	5	5	1	1	0.1
10	120	30	5	10	2	1	0.1
11	120	40	10	5	1	1	0.1
12	120	40	10	10	2	1	0.1

The track behaviour following implementation of such strategies is simulated for 35 years. A set of 1000 simulations have been run for each strategy, thus ensuring convergence of results as shown in Figure 8 where the number of interventions per lifetime averaged over the number of simulations is depicted for all the 12 maintenance strategies.

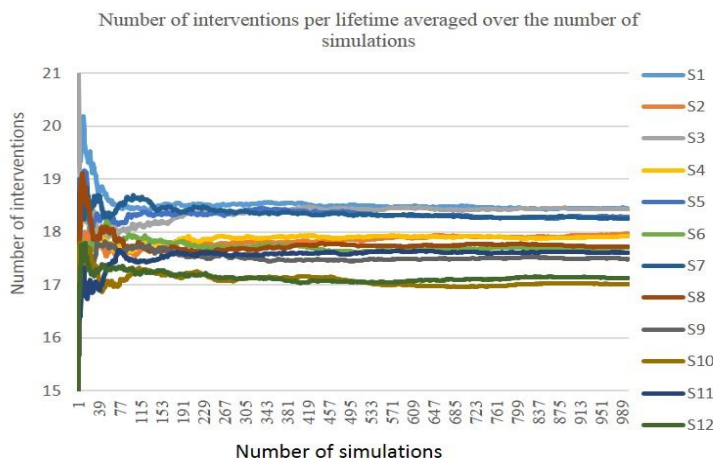

**Figure 8 Average number of interventions per lifetime for each maintenance strategy**

Figure 9 shows the average number of routine maintenance interventions (left) and speed restrictions imposed (right), with consequent emergency interventions, obtained for each maintenance strategy.

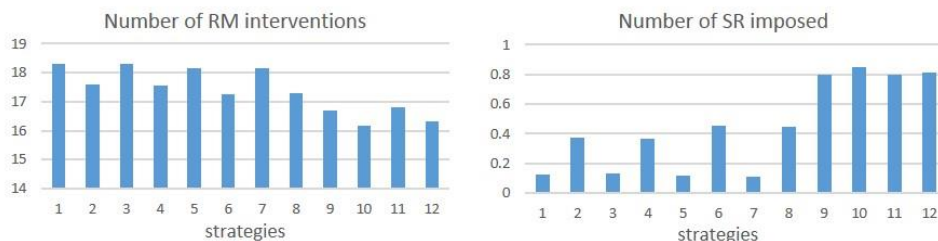

**Figure 9 Number of routine maintenance (RM) interventions (left) and speed restrictions (SR) imposed (right) per lifetime for each maintenance strategy**

The inspection period appears to have a major effect on the number and type of intervention performed. Longer inspection period produces a decrease of the number of routine maintenance interventions and an increase in the number of speed restrictions and consequent emergency interventions. This is because

if inspection is carried out more frequently, degraded states are discovered at an earlier stage and maintenance is performed before the track condition degrades further from a state requiring routine maintenance to a state requiring a speed restriction. Figures 10 also highlights that the probability of the track being in good conditions decreases for longer inspection periods, while the probability of a speed restriction being imposed as well as the probability of being in a condition requiring a speed restriction not yet revealed by inspection, increase with a consequence impact on both service and safety. The mean time to perform routine maintenance also affects the asset response. The probability of being in good condition decreases with longer times for routine interventions, while both the probability of a speed restriction increases.



**Figure 10 Probabilities of good conditions (left), speed restriction imposed (centre) and unrevealed need for speed restriction (right).**

#### 4. CONCLUSIONS

The complexity of the processes involved in the management of the railway system and the many factors contributing to the decisional process of selecting the most cost effective long term intervention strategy for the railway asset, leads to the need for a structured approach to railway asset management. To this aim, this work seeks at laying the foundations for the development of a Railway Asset Management Modelling Framework. The framework will provide the infrastructure operators and the other players involved in the supply chain, with the tools to support a systematic and objective decision making process on assets interventions at the required level (asset/route/network) in order to meet route and network safety and service objectives for the minimum whole life cost. As part of the presented framework, the asset state models play a fundamental role in the prediction of the impact of different maintenance strategies on the assets performance including the probability of the different failure modes. Such predictions can support the selection of the most effective maintenance strategies that contribute to reduce the risk related to the use of the infrastructure. An example of such models is described here for investigating track geometry maintenance options. It is shown how simulation results can be used to compare the effects of different strategies. The probabilities that the track is in a state requiring a speed restriction or a line closure are predicted and the impact of different maintenance strategies to reduce such probabilities can be investigated.

#### Acknowledgements

This research was conducted within the project In2Rail (European Union’s Horizon 2020 research and innovation programme, grant agreement 635900) and will be continued within the Shift2Rail joint undertaking in project In2Smart (European Union’s Horizon 2020 research and innovation programme, grant agreement No: 730569).

#### References

- [1] J. Carretero, J. Perez, F. Garcia-Carballeira, A. Calderon, J. Fernandez, J. Garcia, A. Lozano, L. Cardona, N. Cotaina and P. Prete, “Applying RCM in large scale systems: a case study with railway networks,” *Reliability Engineering and System Safety*, vol. 82, pp. 257-273, 2003.

- [2] M. Macchi, M. Garetti, D. Centrone, L. Fumagalli and G. Padovani, "Maintenance management of railway infrastructure based on reliability analysis," *Reliability Engineering and System Safety*, vol. 104, pp. 71-83, 2012.
- [3] M. Rausand, "Reliability Centered Maintenance," *Reliability Engineering and System Safety*, vol. 60, no. 2, pp. 121-132, 1998.
- [4] T. Murata, "Petri nets: properties, analysis and applications," *Proc IEEE*, vol. 77, no. 4, p. 541–580, 1984.
- [5] R. David and H. Alla, *Discrete, continuous, and hybrid Petri nets*, Springer Science & Business Media, 2010.
- [6] J. Andrews, "A modelling approach to railway track asset management," *Proceedings of the Institution of Mechanical Engineers, Part F: Journal of Rail and Rapid Transit*, vol. 227, no. 1, pp. 56-73, 2013.
- [7] D. Prescott and J. Andrews, "A track ballast maintenance and inspection model for a rail network," *Proceedings of the Institution of Mechanical Engineers, Part O: Journal of Risk and Reliability*, vol. 227, no. 3, pp. 251-266, 2013.
- [8] J. Andrew, D. Prescott and F. Rozières, "A stochastic model for railway track asset management," *Reliability Engineering & System Safety*, vol. 130, pp. 76-84, 2014.
- [9] B. Le and J. Andrews, "Petri-net modelling of bridge asset management using maintenance-related conditions," *Structure and Infrastructure Engineering*, vol. 12, no. 6, pp. 730-751, 2016.
- [10] P. Yanni, D. Rama, L. Neves, J. Andrews and D. Castlo, "A Petri-net approach to railway bridge asset management," *Structure and Infrastructure Engineering*, vol. 13, no. 2, pp. 287-297, 2016.
- [11] B. Le, J. Andrews and C. Fecarotti, "A Petri net model for railway bridge maintenance," *Proceedings of the Institution of Mechanical Engineers, Part O: Journal of Risk and Reliability*, vol. 231, no. 3, pp. 306-323, 2017.
- [12] P. Kilsby, R. Remenyte-Prescott and J. Andrews, "A modelling approach for railway overhead line equipment asset management," *Reliability Engineering and System Safety*, p. In press, 2017.
- [13] M. Audley and J. Andrews, "The effects of tamping on railway track geometry degradation," *Proceedings of the Institution of Mechanical Engineers Part F- Journal of Railway and Rapid Transit*, vol. 227, no. 4, p. 376391, 2013.